

Technical manual for Two-Axis-Counter MC320



Hardware version: 01

Software version: 01

Directory

1.	Safety	4
1.1	Personal qualifications	4
1.2	Proper use	4
1.3	Safety Notes	5
1.4	Safety precautions	5
1.5	Warranty and conditions of supply	5
1.6	Disposal	5
2.	Technical data	6
3.	Commissioning	8
3.1	Installation	8
3.2	Connection	8
3.3	Measuring system supply voltage	12
3.4	Switching input logic	12
3.5	Output logic	12
3.6	Keypad and front panel	13
3.6.1	Display	13
3.6.2	Key functions	13
3.7	Display	14
3.7.1	Standard configuration	15
3.7.2	Difference and sum mode	16
3.8	Menu structure	16
3.8.1	Service level	17
3.8.2	Parameter level	17
3.9	Parameter	17
3.9.1	Entering parameters	18
3.9.2	Parameter function	20
3.10	Parameter lists	20
3.10.1	User parameter	20
3.10.2	Device Parameter	20
3.10.3	Axes parameter	25
4.	Special features	28
4.1	Input functions	28
4.1.1	Inputs 1-4	28
4.1.2	Input 4	29
4.2	Actual value storage	29
4.3	Absolut/Incremental switch	29
4.4	USB-Update	30

5. Illustration list

30

1. Safety

This operating guide contains instructions for ensuring safe and proper installation and operation. If you have any difficulties which cannot be resolved by consulting this guide, please contact the machine manufacturer or vendor for additional information.

hejm Automatisierungstechnik GmbH is not liable for any personal injury or equipment damage resulting from improper commissioning, incorrect operation, misunderstandings or errors contained in this guide or on the display.

hejm Automatisierungstechnik GmbH reserves the right to make technical changes to the equipment or operating guide without prior notice. Therefore, deviations in the agreement between the device and the device description cannot be precluded.

Pay particular attention to hazard notices in this operating guide.

This equipment description should be carefully read before commissioning.

Use of the operating guide presumes corresponding user qualifications.

1.1 Personal qualifications

Commissioning, installation and operation are intended only for appropriately qualified personnel. The personnel must have qualifications which are appropriate to their function and activity, e.g.:

- Instruction and obligation to observe all application-related, regional and in-house regulations and requirements.
- Training in accordance with the standards of safety engineering in the use and maintaining of appropriate safety and occupational health and safety equipment.
- Courses in first aid, etc.

1.2 Proper use

This position display has been developed solely for use on industrial machinery.

Any further use is considered improper. The manufacturer assumes no liability for damages resulting from such misuse. This risk is assumed solely by the user.

1.3 Safety Notes

The following symbols are used for hazards and other important notes:



The **Hazard** symbol warns of errors and hazards in commissioning and operation of the controller. This warning notice means a directly threatening hazard to the health of persons and contains special specifications and instructions as well as imperatives and prohibitions for preventing personal injury and damage to equipment.



The **Attention** symbol means a possible hazardous situation and contains special specifications and instructions as well as imperatives and prohibitions for preventing personal injury and damage to equipment.



The **Note** symbol indicates important and useful information and provides application tips.

1.4 Safety precautions

The device is powered with 24V DC or 90V – 230V AC and must be fused according to prevailing regulations.



When using a 90V - 230V device, the housing must be grounded to avoid electrical shock.

The solder tail on the backside of the housing can be used for this.

1.5 Warranty and conditions of supply

Only the common conditions of supply for manufactures and services of the electrical industry are applied.

The warranty is 2 years.

1.6 Disposal

Do not dispose the device in your general trash. Use gathering places of your community to dispose the electric device.

2. Technical data

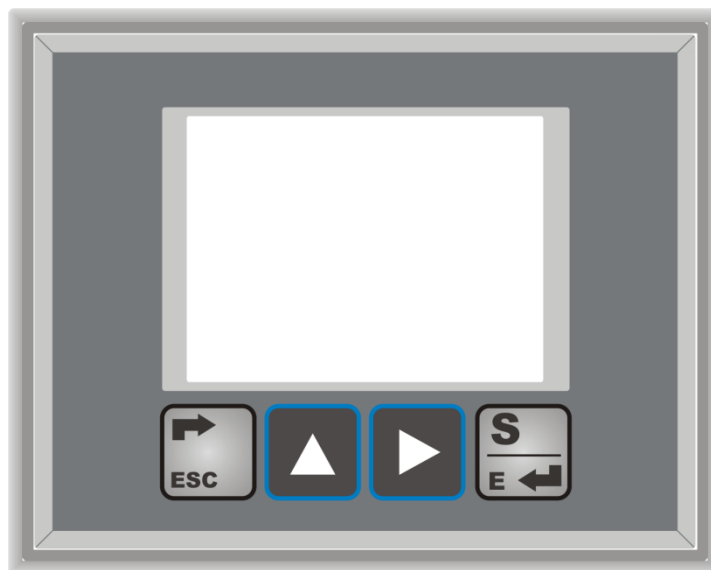

Fig. 1 Dimensions

Supply voltage	24 V DC, or 90V – 230V AC. (please refer to type plate)
Current draw	90mA without any periphery with 24V DC supply or 35 - 20 mA without any periphery with 90V - 230V AC supply. When using a AC device, the current consumption of all connected power consumer must not exceed 300mA
Indicator	2,8" TFT-Display Widescreen 16:10
Input signals	4 digital inputs 0 – 5 V low active 10 - 30 V high active
Measuring system	Incremental measuring system A, A/, B, B/, Z, Z/ Supply voltage 5V or 24V at 24V BDD-Supply voltage Barrier frequency: TBD
Output signals	2 output drivers 24V, 600 mA
Interface	USB, RS232
Operating temperature	TBD
Storage temperature	TBD
Relative humidity	TBD
Mounting orientation	any
Enclosure rating	IP54 on front side, IP00 on back side
Dimensions	116 x 92 x 63 mm ³ (B x H x T)

3. Commissioning



Most damage to the device is a result of faulty wiring and incorrect parameter values. Therefore commissioning is to be performed only by trained and expert personnel.

3.1 Installation

The device is established to a switchboard with a recess of xx,x mm x xx,x mm and has to be screwed in place with the provided mount.

3.2 Connection

The device is powered with 24V DC, or 90V – 230V AC.

Before connecting, compare the part label on the back of the device with the desired connection voltage.



Electrical cables are to be routed in accordance with the respective national regulations (e.g. VDE). Route measuring, signal and power cables separately.

It is recommended to use a screened cable which should be connected with the ground of the device.

Ensure that no ground loops are created.

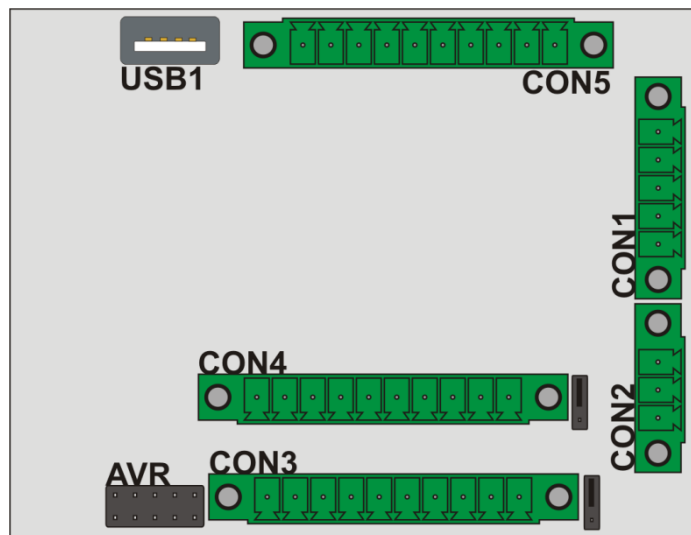

Fig. 2 Connection diagram

Connector and pin definition

Connect supply voltage to the device only as specified on the part label!

CON1 Supply voltage (+24V DC)

Terminal strip 5-pin

Pin 1 GND

Pin 2 GND

Pin 3 GND

Pin 4 +24V

Pin 5 PE

CON1 Supply voltage (90V – 230V AC)

Terminal strip 5-pin

Pin 1 N

Pin 2 Must be left open

Pin 3 Not Connected

Pin 4 L

Pin 5 Must be left open



When a 90V – 230V device is used, the housing must be connected to protection earth!

CON2 RS232 (+24V)

Terminal strip 3-pin

Pin 1	GND
Pin 2	RXD
Pin 3	TXD

CON3 Measuring system 1

Terminal strip 10-pin

Pin 1	GND
Pin 2	Supply voltage measuring system 1 +24V, if jumper is set to +24V +5V, if jumper is set to +5V
Pin 3	Signal A
Pin 4	Signal A/
Pin 5	Signal B
Pin 6	Signal B/
Pin 7	Signal Z
Pin 8	Signal Z/
Pin 9	PE, protective conductor (Shield)
Pin 10	PE, protective conductor (Shield)

CON4 measuring system 2

Terminal strip 10-pin

Pin 1	GND
Pin 2	supply voltage measuring system 2 +24V, if jumper is set to +24V +5V, if jumper is set to +5V
Pin 3	Signal A
Pin 4	Signal A/
Pin 5	Signal B
Pin 6	Signal B/
Pin 7	Signal Z
Pin 8	Signal Z/
Pin 9	PE, protective conductor (Shield)
Pin 10	PE, protective conductor (Shield)

CON5 Inputs/Outputs

Terminal strip 10-pins

Pin 1	Output driver 2, supply voltage 24V DC
Pin 2	Driver output 2
Pin 3	Output driver 1, supply voltage 24VDC
Pin 4	Driver output 1
Pin 5	Switching input 4, input voltage 0 – 24 V RS232 Printer Mode
Pin 6	Switching input 3, input voltage 0 – 24 V
Pin 7	Switching input 2, input voltage 0 – 24 V Axis 2
Pin 8	Switching input 1, input voltage 0 – 24 V Axis 1
Pin 9	GND
Pin 10	+24V

3.3 Measuring system supply voltage

To set the supply voltage to the desired level, the respective voltage must be selected by using the jumper. (Observe data sheet for measuring system!)

To get a 24V measuring system power, the jumper has to be in position 24V.

To get a 5V measuring system power, the jumper has to be in position 5V.

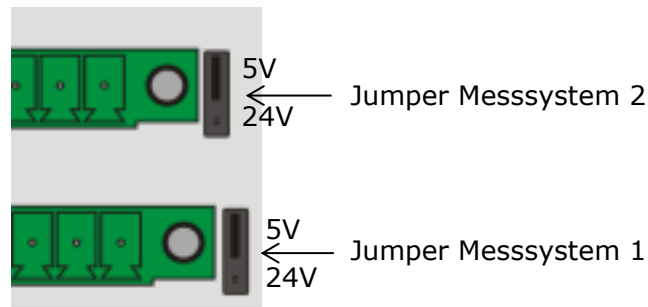

Fig. 3 Measuring system supply voltage

3.4 Switching input logic

The input logic is set through a parameter at the user-parameter menu.

The inputs can switch to GND or +24V

3.5 Output logic

The output logic is set through a parameter at the user-parameter menu.

The outputs can switch to GND or +24V.

3.6 Keypad and front panel

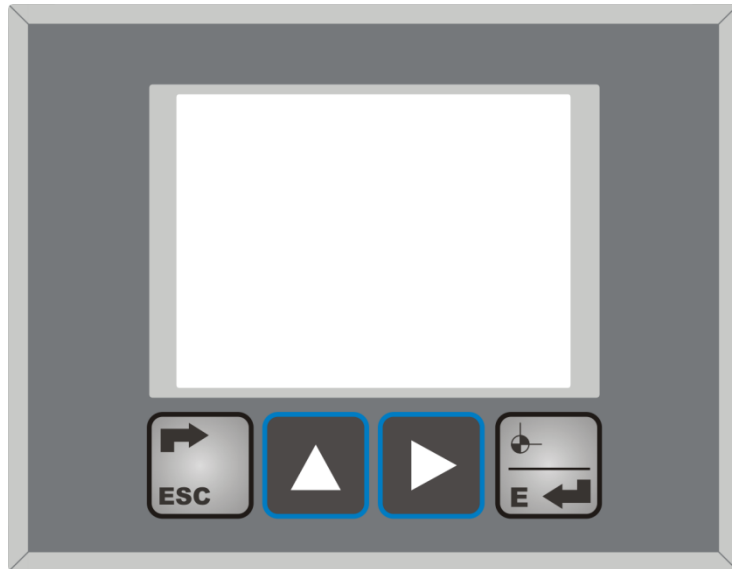

Fig. 4 Front panel MC320

3.6.1 Display

The display is used for visualizing the current position as well as the parameter values in the service levels.

3.6.2 Key functions



Fig. 5 ESC

Pressing the **ESC**-key in the value display , will close it and the service level is called. If the **ESC**-key is pressed in the lowest service level, the value display will be reopened.

Pressing the **ESC**-key will close the active menu and loads the previous menu, or cancels the active operation.



Fig. 6 Up

The **Up**-key is used to select a parameter at the parameter level.

If an input is requested, the chosen decade can be increased by pressing the **Up**-key.

If the cursor is enabled at the counter display, the **Up**-key is used to move the cursor vertically.



Fig. 7 Right

With the **Right**-key it can be switched between the single menu items or is used to jump to the next parameter at the parameter level.

If an input is requested, the cursor can be moved one position to the right by pressing the **Right**-key.

If the cursor is enabled at the counter display, the **Right**-key is used to move it horizontally.



Fig. 8 Enter

At the menu level, the „**Enter**”-key is used to confirm the current selection, which causes to open the next menu level.

At the parameter level, the „**Enter**”-key is used to load the selected parameter, which can be edited afterwards.

After editing a parameter or reference value, the input is confirmed through pressing the „**Enter**”-key. The value will then be saved.

At the normal counter mode, the features of the single display panels can be executed by pressing the „**Enter**”-key. To activate a feature, the panel has to be selected with the cursor.

3.7 Display

After the device started, the display window shows the counter display of the MC530. Depending on the setting of the parameter P29 at the device parameter level, one of the selectable configurations is displayed.

3.7.1 Standard configuration

The standard configuration of the MC320 is a 2-axes-display. Additional to the axis values, the axis symbols and the I/O-states are displayed.

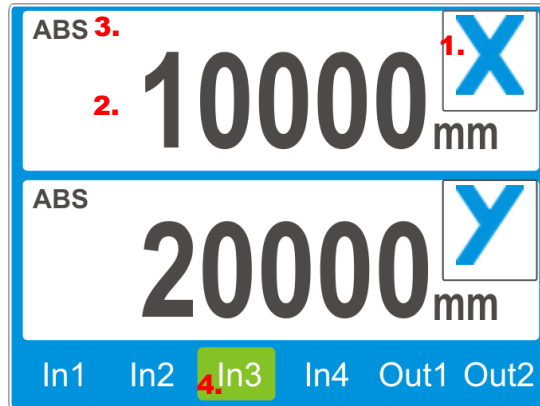







Fig. 9 Standard configuration

1. Axis symbolism
2. Current axis values
3. Absolute/Incremental shift
4. Active input

The cursor is activated through pressing one of the direction keys of the keyboard. The cursor can be moved vertically through the  key and horizontally through the  key. Pressing the  key activates the feature of the selected display field. Only the display fields with the axis symbolism and the absolute/incremental shift can be selected through the cursor.

If a field with an axis symbol is selected, pressing the  key will set the selected axis to the reference value which is deposited at the parameter level. If the axis is in the incremental mode, the axis value will be set to "0".

If the field with the absolute/incremental shift is selected, the displayed axis value can be shifted from absolute to incremental or from incremental to absolute by pressing the  key.

The absolute axis value will be kept, if the value is shifted from absolute to incremental.

The other displayed fields can't be selected with the cursor.

Below the axis symbolism and the axis values are the inputs and outputs displayed. Active inputs and outputs will be marked with green background color and inactive inputs and outputs are deposited with the standard background color of the display.

3.7.2 Difference and sum mode

With the device parameter P29, the display can be switched between the standard 2-axes display and the difference/sum display.

In the difference/sum mode an additional value is displayed below these two axes, which is either the difference or the sum of axis 1 and axis 2. This additional value can be selected through the parameter P56 at the device parameter level.

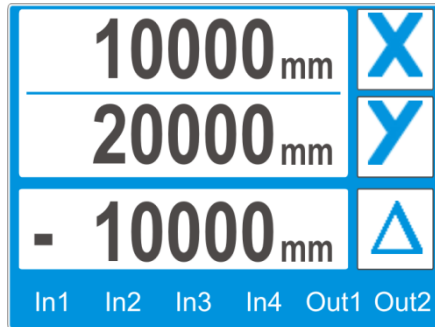

Fig. 10 Difference/Sum mode

By changing the parameter P56, the symbol of the difference and sum counter will also be changed. Also the calculation of the displayed value is changed.



Fig. 11 Difference





Fig. 12 Sum

3.8 Menu structure

The device menu is built-up in several menu levels. After starting the device, the standard display is shown.

Through pressing the  key, the service menu can be reached.

By pressing the  key, a menu item can be selected through the cursor.

By pressing the  key, the selected item will be called.

By pressing the  key, the last menu will be re-opened.

3.8.1 Service level

The menu items **user parameter**, **reference**, **parameter level** and **information** are located at the service level.



Fig. 13 User parameter



Fig. 14 Reference



Fig. 15 Parameter level



Fig. 16 Information

At the **user parameter** you can find parameters for changing the calculation of the measuring system and to change the active language.

At the menu item **reference**, the axes can be referenced individually.

The axis- and device- parameter are located at the **parameter level**.

General information about the device can be found at the menu item **information**.

3.8.2 Parameter level

The parameter level includes the menu items **axis 1**, **axis 2** and **device-parameter**.



Fig. 17 Axis 1



Fig. 18 Axis 2



Fig. 19 Device parameter

The menu items **axis 1** and **axis 2** contain specific parameters to configure the axes.

The **device parameter** contains parameter for general configuration of the device.

3.9 Parameter



When changing control and calibration parameters, always consider the effects on the overall system:

The parameters may be protected against unintended changes by using a security code.

The security code may be selected by the machine manufacturer himself.

3.9.1 Entering parameters

If the parameters have to be changed, the service level has to be opened. Afterwards one of the menu items **user parameter** or **parameter level** has to be opened. If the user parameter was chosen, the parameter choice for device specific functions (e.g. language) is displayed.

If the parameter level was chosen, an additional set of parameters has to be chosen afterwards.

The axis parameters are specific parameters for the respective axis (e.g. encoder direction).

The device parameters include general parameters of the device (e.g. input logic).

If a set of parameters is chosen, the choice has to be confirmed with the -key and the appropriate parameters are displayed.

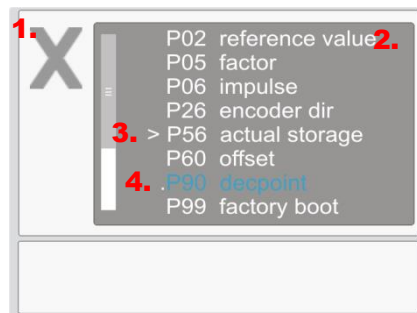



Fig. 20 Parameter selection

1. Active parameter level
2. Parameter list
3. Cursor
4. Parameter that does not correspond to the default settings

At the upper left corner, the symbol shows which set of parameter is displayed.

At the parameter list the available parameters are shown.

The cursor can be moved up with the  key. The cursor is used to select one of the displayed parameters.

A parameter which is different to the default parameter value or got already changed will be deposited with a blue color.

To change the chosen parameter, confirm the choice with the -key. Through the confirmation, the parameter value is called and will be shown at the display.

Depending on the selected parameter, a standard parameter or a multiple choice parameter is displayed instead of the parameter list.

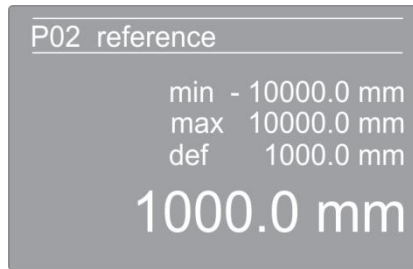

Fig. 21 Standard parameter

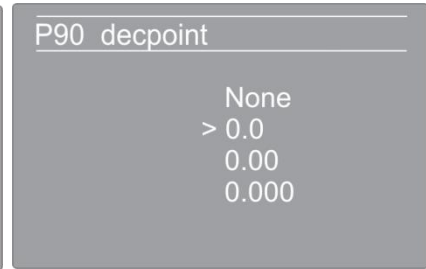



Fig. 22 Multiple choice parameter

Additional to the current value of the standard parameter, the minimum, maximum and default values are displayed

The multiple choice parameter is a selection which can be controlled with the cursor.

Pressing the  key calls the next parameter of the parameter list.

If a standard parameter is chosen, the input mode is activated through pressing the -key and a cursor appears below the current parameter value.

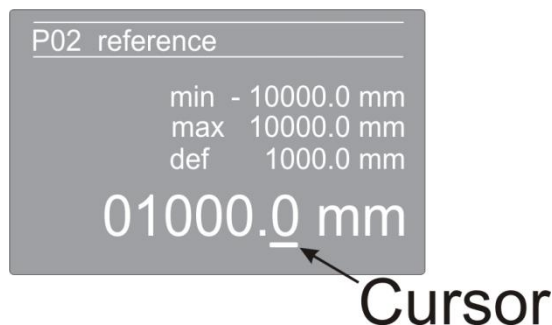







Fig. 23 Parameter input

The cursor can be switched to the next decade by pressing the -key. The chosen decade can be incremented with the -key.

If a negative input is possible, the leading sign can be switched by the cursor. The leading sign will only be displayed with negative values. The leading sign decade is the first decade at the left.

To finish the input confirm the inserted value with the -key. The Value will be saved.

To discard the input value, press the -key. The inserted value will be deleted and the parameter value will be set on the last saved value.

If a multiple choice parameter is chosen, the cursor can be moved up with the -key. Through pressing the -key the current selection will be saved.

With pressing the -key, the current parameter will be closed and the parameter list is displayed.

If the parameters are saved through a security code, the user has to insert the right code before the parameters can be changed. The input of the code works similar as the input of the standard parameter.



Changes in the parameter setting can result in malfunction, stopping or failure. Changes to the parameter settings should therefore be made only by knowledgeable personnel.

3.9.2 Parameter function



The parameters shown in the following are all shown according to the pattern

*Parameter number Name [Unity/ Minimum, maximum Value]
Parameter description*

Parameters in which Pxx is entered as the unit refer to the unit specified in parameter Pxx.

3.10 Parameter lists

3.10.1 User parameter

P00 *Language [Multiple Choice parameter]*

Changing between the available languages

P04 *Adjustment British-Metric [Multiple Choice Parameter]*

Changing between the unity systems. Metric, British and British with rounding

3.10.2 Device Parameter

P09 *Variable Icons [Multiple Choice Parameter]*

If this parameter is set to "On", the standard bitmaps of the axis will be replaced with the bitmaps which were loaded to the device via USB.

If no bitmaps were loaded, the storage of the bitmaps is empty and nothing will be displayed.

(see: *USB-Update*)

P21 *Security code for Parameter [- / 0, 999999]*

Entering a value at this parameter causes that all the parameters of the axis and the device level can be changed only after a security input. The security code is equal to the entered value.

If the value of this parameter is written to "0", the security request is off.

P22 *Security code for reference level [- / 0, 999999]*

Entering a value at this parameter causes that the axes can be referenced through the reference level, only after a security input.

If the value of this parameter is written to "0", the security request is off.

P29 *Display configuration [Multiple Choice Parameter]*

Changing this parameter will change the counter display.

There are 2 different displays, the standard display and the difference/sum display.

P31 *Output 1 low [- / -100000, 100000]*

If the deposited value is exceeded by the displayed value, output 1 will be activated. If the displayed value falls below the deposited value, output 1 will be deactivated. The deposited value has to be lower than the value in parameter P32. If the value of this parameter is the same or higher than the value of P32, output 1 can't switch.

The displayed value is referred to the axis deposited at the parameter P43.

P32 *Output 1 high [- / -100000, 100000]*

If the deposited value is exceeded by the displayed value, output 1 will be deactivated. If the displayed value falls below the deposited value, output 1 will be activated. The deposited value has to be higher than the value in parameter P31. If the value of this parameter is the same or lower than the value of P31, output 1 can't switch.

The displayed value is referred to the axis deposited at the parameter P43.

P33 *Output 2 low [- / -100000, 100000]*

If the deposited value is exceeded by the displayed value, output 2 will be activated. If the displayed value falls below the deposited value, output 2 will be deactivated. The deposited value has to be lower than the value in parameter P34. If the value of this parameter is the same or higher than the value of P34, output 2 can't switch.

The displayed value is referred to the axis deposited at the parameter P44.

P34 *Output 2 high [- / -100000, 100000]*

If the deposited value is exceeded by the displayed value, output 2 will be deactivated. If the displayed value falls below the deposited value, output 2 will be activated. The deposited value has to be higher than the value in parameter P33. If the value of this parameter is the same or lower than the value of P33, output 2 can't switch.

The displayed value is referred to the axis deposited at the parameter P44.

P39 *Interval time output 1 [seconds / 0.00, 2.50]*

The interval time 1 can be chosen between 0 and 2.50 seconds.

The output 1 will be switched as explained at the parameters P31 and P32. However, the output 1 will only be deactivated after expiration of the interval time 1.

P40 *Interval time output 2 [seconds / 0.00, 2.50]*

The interval time 2 can be chosen between 0 and 2.50 seconds.

The output 2 will be switched as explained at the parameters P33 and P34. However, the output 2 will only be deactivated after expiration of the interval time 2.

P43 *Reference to Output 1 [- / Multiple Choice Parameter]*

With this parameter an axis can be selected to which output 1 refers to.

P44 *Reference to Output 2 [- / Multiple Choice Parameter]*

With this parameter an axis can be selected to which output 2 refers to.

P54 *Key function [Multiple Choice Parameter]*

The -key can be assigned with additional function.

If this parameter is set to “mm inch”, the displayed values can be switched from mm to inch respectively from inch to mm by pressing and holding the -key for 2 seconds.

P56 *Count mode [- / Multiple Choice Parameter]*

The difference/sum value can only be displayed if the configuration „dif. sum “ is selected through the parameter P29.

Differential counter:

Difference Value = Current value of axis 1 – Current value of axis 2

Sum counter:

Sum Value = Current value of axis 1 + Current value of axis2

It is important that the unity and the resolution (decimal point) of the axis are similar.

According to the selected mode of this parameter, a difference or sum symbol will be displayed with the calculated value.

P60 *Function input 1 [- / Multiple Choice Parameter]*

This parameter controls how the display of axis 1 is affected by the input 1. (see 4.1. Input functions)

P61 *Function input 2 [- / Multiple Choice Parameter]*

This parameter controls how the display of axis 2 is affected by the input 2. (see 4.1. Input functions)

P62 *Function input 3 [- / Multiple Choice Parameter]*

This parameter controls how the display of axis 1 is affected by the input 3. (see 4.1. Input functions)

P63 *Function input 4 [- / Multiple Choice Parameter]*

This parameter controls how the display of axis 2 is affected by the input 4. (see 4.1. Input functions)

If the parameter P85 “RS232 mode” is set to mode 2, the input 4 is used to transmit the current values via RS232 interface. The here selected input mode will not be considered.

P86 *Printer time [seconds/ 0.50, 650.00]*

The stored parameter value is only used if the operating mode of the RS232 interface is set to "Mode1".

The time deposited in this parameter equates the cycle duration of the periodically transmission for the Print Mode 1 of the RS232 interface.

P99 *Factory boot [- / Multiple Choice Parameter]*

Selecting the factory boot will set all parameters to their default value.

3.10.3 Axes parameter

P02 *Reference value [P91 / -99999, 999999]*

Value the counter proposes when the reference level is activated or the axis is set to when the Set function is activated.

P05 *Travel distance for factor calculation [Length / 1, 999999]*

Contains any desired travel distance.

The device requires these two parameters in order to be set for various mechanical variations such as drives, spindle travel, etc.

1. Any desired travel distance in the desired unit and resolution (P05).
2. The number of pulses sent from the measuring system to the controller when traveling this distance (P06).

The controller can count without error over the entire range only if these data are entered in P05 and P06 without rounding error.

Therefore you should always select a travel distance for which a whole-number of pulses is sent by the measuring system.

P06 *Impulse / Travel distance [measuring system resolution / 1, 999999]*

Number of pulses per travel distance specified in P05 (the factor is automatically calculated from P05 and P06).

Example 1: The measuring system in use sends 100 pulses to the controller over a distance of 1.00 mm. Setpoints, actual values, etc. should be send in increments of 1/100 mm. This means each pulse arriving from the measuring system must be offset against the actual value. Therefore P05 and P06 should be set to the same value (e.g. 1, 1 or 10,10 resp. 100, 100).

Example 2: The system again has a resolution of 1/100 mm. Setpoints and actual values should resolve however only

to one decimal place, i.e. in 1/10 mm. This means that over a distance of 1 (0.1 mm) 10 pulses are sent from the measuring system to the controller. Therefore set P05 to a factor of 10 less than P06 (e.g. 1, 10 or 10,100 resp. 100, 1000).

Example 3: A machine with spindle drive has the following benchmark data: Spindle pitch 5.0 mm / Encoder with a resolution of 20 pulses per revolution. You want setpoints and actual values to be resolved to one decimal place, i.e. in 1/10 mm. This means that over a distance of 50 (5.0 mm) 20 pulses are sent from the measuring system to the controller. Therefore you should set P05 to 50 and P06 to 20.

P26 *Encoder direction [- / Multiple Choice Parameter]*

Changing this parameter causes the count direction to be reversed.

P40 *Measuring system selection [- / Multiple Choice Parameter]*

The device can operate with measuring systems whose supply voltage and signal level is 5V or 10-30V.

The measuring system supply voltage can be set using jumpers on the rear side.

When using 5V systems, always make sure that tracks A, B Z and their inversions are connected in order to prevent problems.

A B Z: Only tracks A, B and Z are evaluated.

AA BB ZZ: Tracks A, A/, B, B/ and Z, Z/ are processed.

P56 *Actual value storage [- / Multiple Choice Parameter]*

The storage for the actual value is by default active.

If the storage is deactivated, the user is requested to reference the axis after the start of the device.

P60 *Offset [P91 / -10000, 10000]*

Enter the offset dimension in units of length, such as xx.x mm or x.xx inches.

This value is subtracted from the display value when the offset measurement contact is activated.

When the input is deactivated the value is added again.

P67 *Saw blade correction [P91 / -10000, 10000]*

This value will be subtracted from the displayed value, if the set or reset function is triggered in the incremental mode.

P90 *Decimal point [- / Multiple Choice Parameter]*

With this parameter you can select if and how the decimal point is displayed with the axis value.

The setting of the decimal point has no affection on the resolution of the display. The resolution is set through the parameter P05 and P06.

P99 *Factory boot [- / Multiple Choice Parameter]*

Selecting the factory boot will set all parameters to their default values.

4. Special features

4.1 Input functions

4.1.1 Inputs 1-4

The inputs 1-4 of the MC320 can be occupied with different functions. Each of the 4 inputs refers to another axis:

Input 1 – Axis 1 – Device parameter P60

Input 2 – Axis 2 – Device parameter P61

Input 3 – Axis 1 – Device parameter P62

Input 4 – Axis 2 – Device parameter P63

Function	Description
Static reset	Sets the actual value of the referred axis to "0" and holds the actual value at "0" as long as the input is active.
Edge triggered reset	Sets the actual value of the referred axis to "0" if a rising or falling edge of the input is recognized. (Depending on the settings of the device parameter P70, the input will trigger on a falling or rising edge)
Static set	Sets the actual value of the referred axis to the deposited reference value of the axis parameter P02 and holds the actual value at the reference value as long as the input is active.
Edge triggered set	Sets the actual value of the referred axis to the deposited reference value of the axis parameter P02 if a rising or falling edge of the input is recognized. (Depending on the settings of the device parameter P70, the input will trigger on a falling or rising edge)
Offset	The in the axis parameter P60 deposited offset value will be allocated with the actual value as long as the input is active.
Counter stop	As long as the input is active, the counter will be stopped. The actual value of the referred axis will stay on its last value until the input goes inactive. As long as the input is active, incoming pulses of the encoder will be ignored.

Counter freeze	If the input goes active, the actual value of the referred axis will be frozen until the input goes inactive. The counter will still run in the background.
----------------	---

The inputs 3 and 4 have a higher priority than the inputs 1 and 2.

Example:

Input1 is used as static reset, input 3 is used as static set. If the inputs are switched active in the same time, the value of the axis 1 is set to the reference value due the higher priority of the input 3.

4.1.2 Input 4

If the mode of the RS232 interface is set to mode 2 via the device parameter P85 "RS232 Mode", activating the input 4 will start a transmission of the current display values via RS232 interface.

The standard function of the input is disabled, as long as the input is used for the transmission of the current values.

4.2 Actual value storage

The actual value storage is individually activated/deactivated for every axis through the axis parameter P56 "Actual value storage". The actual value storage is active by default, therefore it has not to be considered.

If the actual value storage is deactivated, a small reference symbol is blinking near the referred axis value. This symbol indicates that the actual value storage is deactivated and the referred axis should be referenced before further operations.

4.3 Absolut/Incremental switch

The current values of the standard display can be switched from absolute to incremental, respectively from incremental to absolute.



If the set function is called in the incremental mode, the reset function will be executed, as the set function is forbidden in the incremental mode.

4.4 USB-Update

The device MC320 comes with an USB interface.

With this interface updates, bitmaps and other data can be transferred to the device.

The USB menu will open as soon as the device detects a plugged in USB-stick.

Information to the execution of an update and the transmission of the other data can be found in the manual "Device update via USB-Interface".

5. Illustration list

Fig. 1 Dimensions.....	6
Fig. 2 Connection diagram.....	8
Fig. 3 Measuring system supply voltage.....	12
Fig. 4 Front panel MC320	13
Fig. 5 ESC.....	13
Fig. 6 Up	13
Fig. 7 Right.....	14
Fig. 8 Enter	14
Fig. 9 Standard configuration.....	15
Fig. 10 Difference/Sum mode	16
Fig. 11 Difference.....	16
Fig. 12 Sum	16
Fig. 13 User parameter	17
Fig. 14 Reference.....	17
Fig. 15 Parameter level.....	17
Fig. 16 Information	17
Fig. 17 Axis 1.....	17
Fig. 18 Axis 2.....	17
Fig. 19 Device parameter	17
Fig. 20 Parameter selection	18
Fig. 21 Standard parameter	19
Fig. 22 Multiple choice parameter	19
Fig. 23 Parameter input.....	19